

# AT-320240Q3

• 320 x 240 dots 1/240 Duty

## FEATURE

1. Construction : FSTN LCD, TAB IC, LED Backlight, Bezel and PCB.
2. Option : Touch Panel, Touch Panel Controller.
3. Built-in Controller / Pure driver.
4. 5V or 3.3V single power input, Built-in DC/DC converter for LCD driving.
5. Normal / Extended temperature type.

## ELECTRICAL CHARACTERISTICS

Parameter	Symbol	Condition	Typ.Value	Unit.
LCD Driving Voltage	VLCD	25°C	22.9	V
Supply Current (Controller)	IDD	VDD=3.3V	20	mA
Supply Current (Driver)	IDD	VDD=3.3V	1.5	mA

## POWER SUPPLY

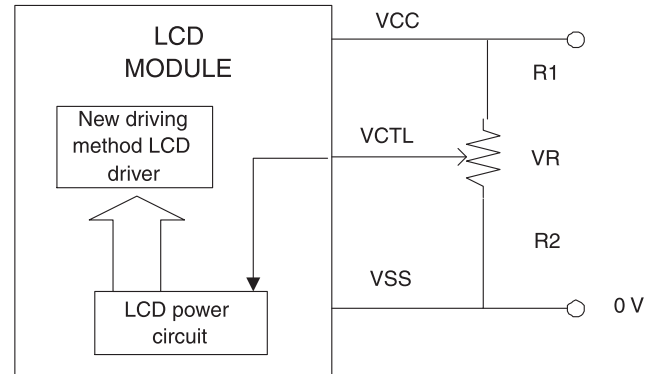

## INTERFACE

1	2	3	4	5	6	7	8	9	10	11	12
/RESET	/RD	/WR	/CS	A0	DB0	DB1	DB2	DB3	DB4	DB5	DB6
13	14	15	16	17	18	19	20	21	22	23	24
DB7	VDD	VSS	VCTL	NC	SK	DO	DI	CS	INT	A	K

## PURE DRIVER

1	2	3	4	5	6	7	8	9	10	11	12
D0	D1	D2	D3	/DISPOFF	FLM	M	LP	CP	VCC	VSS	NC
13	14	15	16	17	18	19	20	21	22	23	24
VCTL	/RESET	SK	DO	DI	CS	INT	A	K	NC	NC	NC

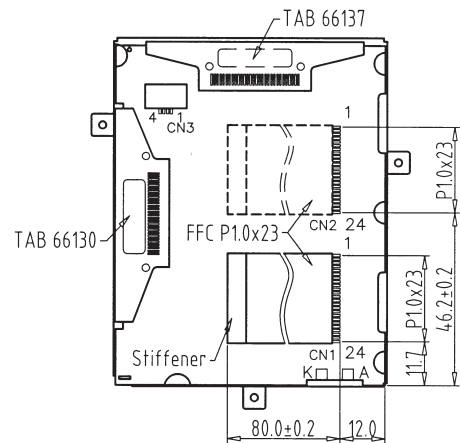
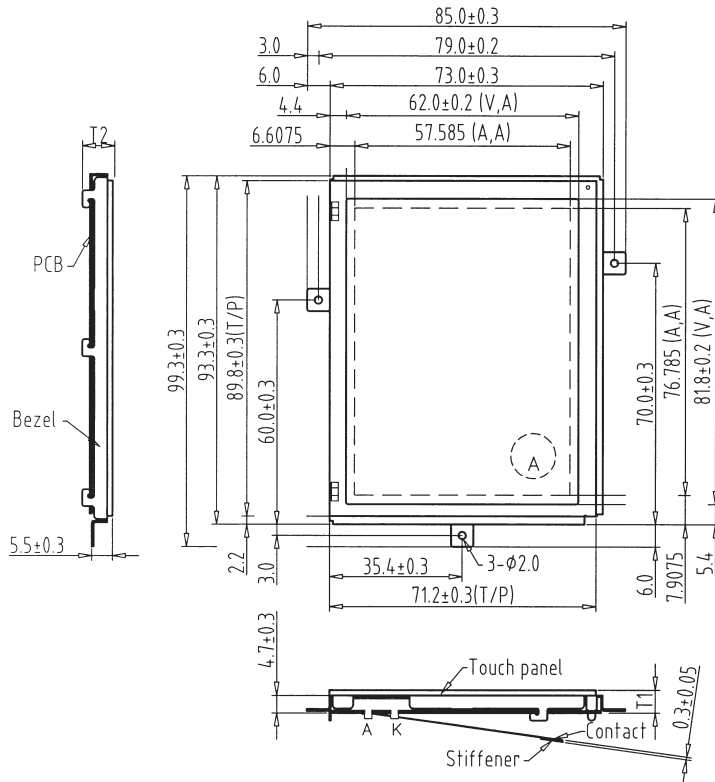

Back view

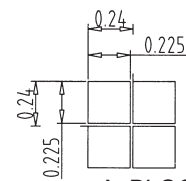

A BLOCK

### THICKNESS:

VERSION	T1	T2
EL BACKLIGHT	4.2 ± 0.3	6.7 ± 0.3
Touch Panel	6.1 ± 0.3	8.6Max

### Connector

CN1/2: Molex:52207-2490  
AMP:2487951-4