

Fuente de alimentación para los motores

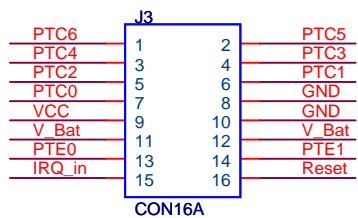

Controladores de los motores

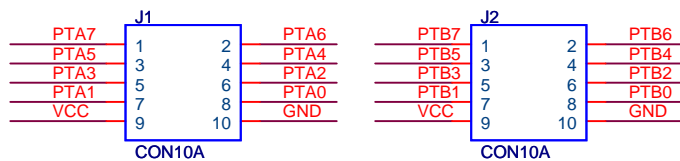
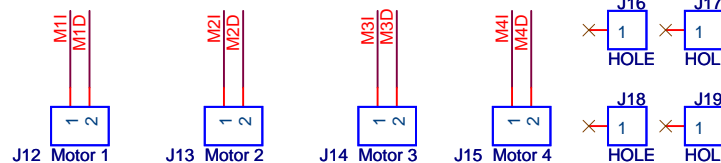
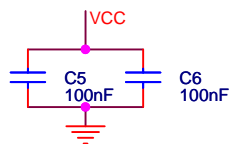
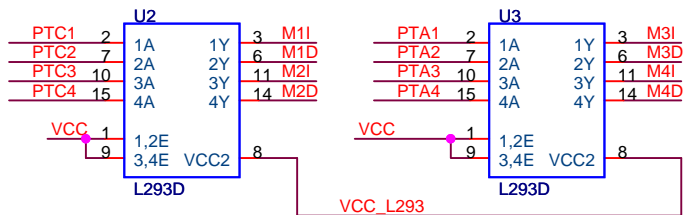

Bornas para los 4 motores

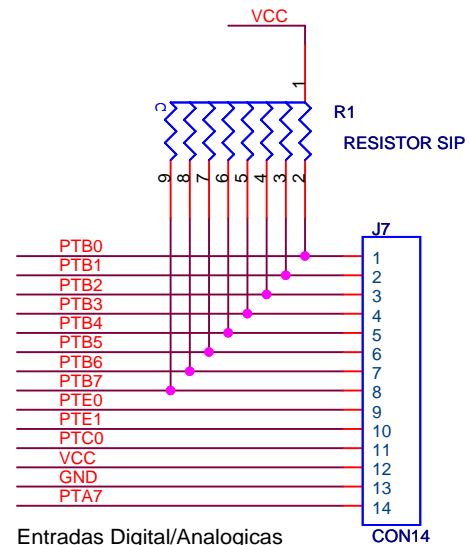

Entradas Digital/Analógicas  
(R de pull up internas al micro para entradas digitales. Para las entradas analógicas usar las que corresponda, conectandolas al zocalo del array de resistencias)

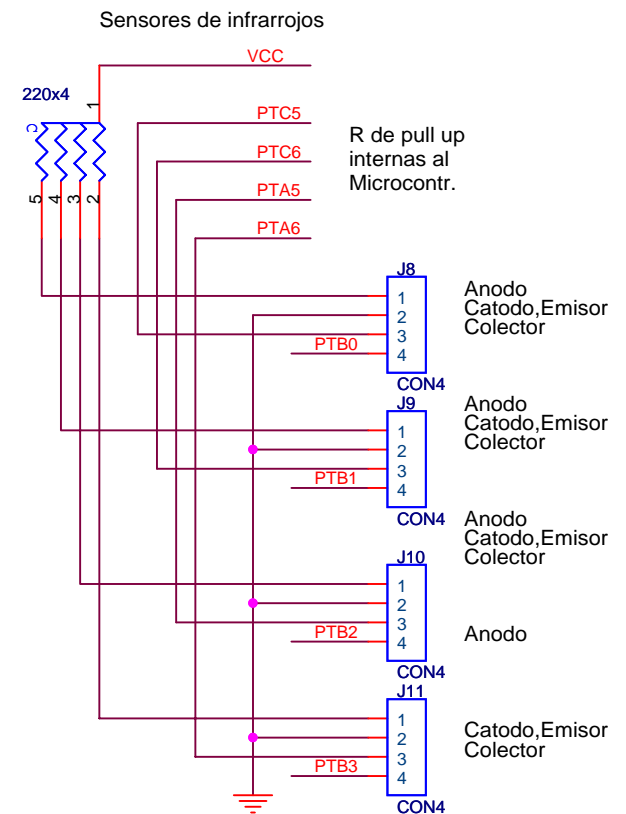

Sensores de infrarrojos